



(11) **EP 3 103 944 B1**

(12) **EUROPEAN PATENT SPECIFICATION**

(45) Date of publication and mention of the grant of the patent:
11.07.2018 Bulletin 2018/28

(51) Int Cl.:
E05B 35/00^(2006.01) E05B 27/00^(2006.01)

(21) Application number: **15171984.6**

(22) Date of filing: **12.06.2015**

(54) **KEY WITH A PIVOTING ELEMENT AND A LOCK**

SCHLÜSSEL MIT EINEM DREHBAREN ELEMENT UND EINEM SCHLOSS

CLÉ AVEC UN ÉLÉMENT PIVOTANT ET UN VERROU

(84) Designated Contracting States:
AL AT BE BG CH CY CZ DE DK EE ES FI FR GB GR HR HU IE IS IT LI LT LU LV MC MK MT NL NO PL PT RO RS SE SI SK SM TR

(43) Date of publication of application:
14.12.2016 Bulletin 2016/50

(73) Proprietor: **SEA Schliess-Systeme AG**
3052 Zollikofen (CH)

(72) Inventor: **Tahiri, Fatmir**
3302 Moosseedorf (CH)

(74) Representative: **Veni**
Swiss & European Patent Attorneys
Villa de Meuron
Buristrasse 21
3006 Bern (CH)

(56) References cited:
EP-A1- 0 890 694 EP-A2- 0 213 069
WO-A1-2015/063755 GB-A- 2 058 199
JP-U- S62 149 561

EP 3 103 944 B1

Note: Within nine months of the publication of the mention of the grant of the European patent in the European Patent Bulletin, any person may give notice to the European Patent Office of opposition to that patent, in accordance with the Implementing Regulations. Notice of opposition shall not be deemed to have been filed until the opposition fee has been paid. (Art. 99(1) European Patent Convention).

Description

TECHNICAL FIELD

[0001] The present invention relates to a lock, a key comprising a pivoting element and to a method of coding the key.

BACKGROUND OF THE INVENTION

[0002] In the last couple of decades many new optimisations and improvements have been introduced in the field of cylinder locks and keys with the main purpose of increasing the number of lock combinations and/or the complexity of mechanical key geometries. Many significant electronic features have also been introduced to mechanical cylinder locks in this way enhancing the security based on electronic devices, which relied on external electrical supply.

[0003] Some typical optimisations which involve increasing the number of lock combinations on mechanical keys and/or cylinder locks are:

- increasing the number of interacting components, such as pins and cavities and/or tumbler pins and cavities;
- varying and/or increasing the complexity of the shape of the pins, tumbler pins, keys and/or the corresponding channels in the cylinder lock;
- manufacturing keys with at least one static vacancy with a special form, which reacts with their counteracting parts in the cylinder lock.

[0004] These types of mechanical improvements have made the reproduction of keys and cylinder locks by unauthorised third parties more difficult. However, these improvements do not comprise an active moving element which may make the cloning of these parts with conventional machines faster and simpler. The geometry of a key can as well be interpreted by an expert who is then able to clone a key with either rapid prototyping machines or conventional machines.

[0005] As commonly known, cylinder locks comprise at least one housing and/or a stator, which contains a rotor, sometimes also referred to as a plug, arranged to rotate within the cylinder. At least one row of cavities or one row of stator through holes is defined inside the stator, and at least one row of rotor through holes, rotor channels and a key channel are defined in the rotor. Rotor pins are accommodated in the rotor through holes, such that one end of each rotor pin is arranged to protrude into the key channel. Stator pins, supported by springs, are accommodated in the cavities, which may be blind holes. Tumbler pins are accommodated in the rotor channels. The ends of the tumbler pins are arranged to protrude into cavities in the stator. The corresponding key has a

row of teeth or dimples defined along the top/and bottom edge and grooves on the lateral sides of the key shaft, which is inserted into the key channel of the lock. The row of rotor pins engages with the teeth or dimples of the key, and the row of tumbler pins engages with the grooves of the key. When the key is fully inserted in the key channel, causing the plane of contact between the rotor pins and the stator pins and between the tumbler pins and the key grooves to align with the plane of contact between the rotor and the stator. When this alignment occurs on all the rotor pins and tumbler pins, the rotor becomes free to rotate in the cylinder. The rotation of the cylinder is used to operate a further mechanism, such as a cam for moving a dead bolt element and thereby unlocking a door.

[0006] The disadvantage of this type of lock and key is that the key can be reproduced by unauthorised third parties using a series of relatively simple machining operation such as milling and drilling. Some solutions have been proposed to overcome this problem, as known for example from Spanish patent application ES2088345. However, the solution proposed in ES2088345 is not optimal, since the key is not reversible, and also in terms of coding permutations the key and/or lock design is not optimal, since the moving part on the lateral side of the key reduces the permutation ability, because the moving part uses a part of the key in which a key coding could have been stored. Another solution is proposed in EP0416500, however, this solution does not overcome the drawbacks of ES2088345. Furthermore, the solution disclosed in EP0416500 is complicated in that it requires auxiliary holes in the rotor and lock cylinder, perpendicular to and on opposite sides of a plane defined by the key channel. The auxiliary holes are arranged to accommodate auxiliary pins and springs.

[0007] WO2015/063755 discloses a key having an encoding moveable element. The key according to WO2015/063755 comprises: a blade; a plurality of encoding bores in the blade; and wherein at least one of the encoding bores is designed to allow a corresponding pin of a lock thereof to cross an entire thickness of the blade, thereby increasing the number of encoding combinations of the lock.

[0008] EP0890694 discloses a cylinder lock with a flat key for insertion into a key channel of the cylinder lock, into which key channel tumbler pins and at least one supplementary tumbler pin project, and the supplementary tumbler pin when the key is fully inserted is displaceable into a release position by a lifting flank of a two-armed pivoted lever. The pivoted lever is disposed in an opening of the key bit and is capable of swivelling about an axis extending at right angles to the insertion direction, the swivelling of the pivoted lever being effected by the action of a control flank of the pivoted lever upon a cam. The lifting flank and the control flank are associated with different arms and tumbler pin and cam are associated with the same key channel wall.

[0009] It is an object of the present invention to over-

come the problems identified above related to cylinder locks and associated keys.

SUMMARY OF THE INVENTION

[0010] According to a first aspect of the invention, there is provided a key for a cylinder lock as recited in claim 1.

[0011] According to a second aspect of the invention, there is provided a cylinder lock as recited in claim 10. According to a third aspect of the invention, there is provided a method of coding a key as recited in claim 12. With the proposed new solution more advantages are attained through further developments, in which enhancements are made to increase the safety of key blanks, keys and/or locks by using mechanical means.

[0012] The proposed new solution has therefore the advantage that key blanks, keys and/or the cylinder locks are more difficult to reproduce by unauthorised third parties, due to the inclusion of a force transferring means such as a pivoting element. Furthermore, the inventive key and lock provide increased security, because the force transferring means can be used to code the key. Furthermore, fraudulent opening of the lock is made more difficult, because at least one of the rotor pins has to be in a recessed position in its through hole in order to rotate the rotor. Moreover, the proposed key may be reversible.

[0013] Other aspects of the invention are recited in the dependent claims attached hereto.

BRIEF DESCRIPTION OF THE DRAWINGS

[0014] Other features and advantages of the invention will become apparent from the following description of a non-limiting exemplary embodiment, with reference to the appended drawings, in which:

- Figure 1 is a simplified cross-sectional side view of a cylinder lock mechanism together with associated keys taken in a vertical plane along the longitudinal axis of the key channel;
- Figure 2 is a cross-sectional view of a cylinder lock mechanism together with an associated key taken in a plane orthogonal to the longitudinal axis of the key channel;
- Figure 3 is an isometric view of a key according to an embodiment of the present invention;
- Figure 4 is an isometric view of the key of Figure 3, showing the pivoting element in a different position;
- Figure 5 is a cross-sectional side view of the key of Figure 3 taken in a vertical plane along the longitudinal axis of the key;
- Figures 6a to 6c are cross-sectional side views of a part of the lock mechanism of Figure 1 together with

a key, taken in a vertical plane along the longitudinal axis of the key, and showing the process of inserting the key into the key channel;

- 5 • Figure 7 is an enlarged cross-sectional side view of a part of the cylinder lock mechanism together with the associated key, taken in a vertical plane along the longitudinal axis of the key, according to a variant of the present invention;
- 10 • Figure 8 is an enlarged cross-sectional side view of a part of the cylinder lock mechanism together with the associated key, taken in a vertical plane along the longitudinal axis of the key, according to another variant of the present invention;
- 15 • Figure 9 is a cross-sectional side view of a key, taken in a vertical plane along the longitudinal axis of the key, according to another variant of the present invention;
- 20 • Figure 10 is a cross-sectional side view of a key, taken in a vertical plane along the longitudinal axis of the key, according to another variant of the present invention;
- 25 • Figure 11 is an isometric view of a key according to another variant of the present invention;
- 30 • Figure 12 is an isometric view of a key according to another variant of the present invention;
- Figure 13 is an isometric view of a key according to another variant of the present invention;
- 35 • Figure 14 is an enlarged cross-sectional side view of a part of the cylinder lock mechanism together with the associated key, taken in a vertical plane along the longitudinal axis of the key, according to another variant of the present invention;
- 40 • Figure 15 is an enlarged cross-sectional side view of a part of the cylinder lock mechanism together with the associated key, taken in a vertical plane along the longitudinal axis of the key, according to another variant of the present invention;
- 45 • Figure 16 is a cross-sectional view of a cylinder lock mechanism together with an associated key, taken in a plane orthogonal to the longitudinal axis of the key channel, according to another variant of the present invention; and
- 50 • Figure 17 is a cross-sectional view of a cylinder lock mechanism together with an associated key, taken in a plane orthogonal to the longitudinal axis of the key channel, according to another variant of the present invention.
- 55

DETAILED DESCRIPTION OF AN EMBODIMENT OF THE INVENTION

[0015] An embodiment of the present invention will now be described in detail with reference to the attached figures. This embodiment is described in the context of mechanical keys and mechanical cylinder locks, but the teachings of the invention are also applicable to mechatronic keys and mechatronic cylinder locks. Identical or corresponding functional and structural elements which appear in the different drawings are assigned the same reference numerals.

[0016] Figure 1 shows a cross-sectional side view of a double cylinder lock 1 in which authorised keys 3a, 3b, also called safety keys, are inserted in the key channels 5 (see Figure 6a), also known as a key slot, key hole or key way. The double cylinder lock 1 comprises two cylinder locks 1a, 1b, which are connected to each other by a crosspiece 2. Both locks 1a, 1b comprise a mechanical key coding system following e.g. the principles disclosed in CH4077989. The lock 1a on the right further comprises an additional mechatronic system having a coding scheme e.g. according to WO98/28508. In the following description, for simplicity, only the lock 1a and the mechanical key 3a on the right are described in more detail. However, the teachings below also apply to the lock 1b and the mechatronic key 3b on the left.

[0017] In Figure 1 there is also shown a housing 7, in which stators 8 are provided. The stator 8 is fixed in the housing, or may be of one piece with the housing, and is not arranged to rotate or move in another manner. A rotor 9 is located in the stator 8 such that the rotor 9 is axially fixed but rotatable within the stator 8. It is to be noted that in some configurations the stator and housing may be merged into one element. The stator has cavities or channels, in this case located radially with respect to the longitudinal axis of the stator. In this example, the cavities are aligned in one row, but other configurations of the cavities are also possible. Stator pins 11, also known as housed pins, are provided in the cavities. Each stator pin 11 is supported by a biasing means 12, in this example a compression spring, hereinafter simply referred to as a spring. The springs are arranged to urge the stator pins 11 towards the key channel 5. The stator pins 11 in turn cooperate with rotor pins 13 accommodated in rotor pin channels, referred to as through holes, or simply pin channels and located radially in the rotor 9. The distal ends of the rotor pins 13 are arranged to engage with the key 3a in the key channel 5, as explained later in more detail. When the proximal ends (the ends in contact with the stator pins) of the rotor pins 13 are substantially flush with the rotor outer surface, the lock 1a can be unlocked by rotating the rotor within the stator 8. The turning of the rotor causes a cam 14 cooperating with a coupling unit 15 to rotate so that the cam can engage with a door latch, for example. In the configuration of Figure 1, the rotor is in its unlocking state. However, when there is no key 3a in the key channel 5, the rotor

pins 13 are biased against a shoulder stop in the through holes, the rotor pins and the shoulder stops being such that the proximal ends of the rotor pins 13 are not flush with the rotor outer surface, and the rotor pins therefore block the rotation of the rotor, so that the lock 1a cannot be unlocked.

[0018] In Figure 1 there are shown two types of keys, namely a mechanical key on the right 3a and a mechatronic key on the left 3b. The mechatronic key has an electronic structural element 16a and may as well have an electric circuit 16b. The electronic structural element 16a and/or the electric circuit 16b can communicate with an electronic control device (not shown), such as an RFID reader (not shown), which may either be comprised in the lock or be a part of the lock as an outstanding member. In this manner the electronic structural element 16a, the electric circuit 16b, and the electronic control device comprise the key coding. In order to be able to unlock the cylinder lock 1b, the mechatronic key 3b has to be fully inserted in the key channel 5 in order to first unlock the mechanical locking mechanism. The electronic structural element 16a and/or the electric circuit 16b communicate(s) with the electronic control device (not shown), which in turn will change the state of a locking unit device 17 to an unlocking state, or when the key coding is not recognised, the locking unit device 17 remains in a locking state. The data exchange between the key 3b and the cylinder lock can either be hard-wired or by radio transmission, which means that the mechatronic key 3b does not have to be inserted into the key channel 5 in order to change the state of the locking unit device 17. In Figure 1 the keys 3a and 3b are further shown to comprise force transferring means 31 of which the purpose will be explained later.

[0019] Figure 2 shows a cross-sectional view of the lock mechanism, taken through the first rotor pin 13 from the right in Figure 1 in a plane orthogonal to the plane defined by the longitudinal axis of the key channel 5. As shown, in this configuration the rotor pins 13 are aligned with the key 3a. In other words, the longitudinal axis of the blind holes is aligned with the key shaft 22 as viewed in the cross-section. Figure 2 also shows a safety ring 18, which fixes the rotor 9 to the stator 8. The safety ring 18 is fitted in place with two safety springs 19 and one safety screw 20. The safety springs 19 ensure that the safety ring is kept under pre-tension. The safety ring 18 ensures that the rotor 9 is kept in the stator 8 and cannot be fraudulently dismounted. Without the safety ring 18, the rotor 9 could theoretically fall out of the stator 8. The structure of the key 3a is explained next in more detail with reference to Figures 3 to 5.

[0020] Figure 3 is an isometric view of the key 3a according to an embodiment of the present invention. The key 3a comprises a grip head 21 connected to a key shaft 22, also known as a key blade, body or shank. In this example the key shaft 22 has a substantially rectangular cross-section, but other cross-sectional shapes, such as a substantially circular shape, are also possible. The key

3a further comprises pin-engaging means, referred to as dimples 25, on the top and/or bottom edge of the shaft 22 which are arranged to engage with the rotor pins 13 when the key shaft 22 is inserted into the key channel 5 of the lock. In this example, the lateral side(s) of the shaft 22 comprises two grooves 27 to engage with further validating means 30, known as tumblers (see Figure 6a) in the rotor 9. However, the teachings of the invention would also apply to keys with no grooves, or having a number of grooves other than two, for example one groove, possibly on either lateral side of the shaft. Instead of, or in addition to, the groove(s), the lateral side(s) could comprise further dimples, cavities and/or protrusions. In Figure 2, a longitudinal axis 29 of the key 3a is also illustrated. This axis 29 substantially coincides with the longitudinal axis of the key channel when the key is in the key channel 5. By moving the key along this axis 29, in this example to the left in Figure 3, the key can be inserted into the key channel 5.

[0021] According to the present invention, the key 3a, and more specifically the key shaft 22, comprises force transferring means 31, in the form of a pivoting element. The force transferring means 31 may also be called an active moving element, since it is arranged to be actively urged by at least one rotor pin 13 as explained later more in detail. The pivoting element 31 may at least be partly made of metal, plastic or ceramic, or a combination thereof. In the examples discussed below, the key 3a comprises at least two substantially identical pivoting elements 31 to make the key reversible, but the teachings of the present invention are not limited to keys with two pivoting elements. For example, the number of the pivoting elements could be one, or more than two, as explained later in more detail. The pivoting element is provided in a cavity 33, better shown for example in Figure 5. According to this example, the pivoting element 31 is held in place by holding means, such as a rivet. In this example the pivoting element 31 is arranged to rotate or pivot about a rotation axis 37, which coincides with the length axis of the rivet 35. The holding means (rivet 35) may or may not pass through the whole lateral cross section of the key. In another variant, the rotation axis 37 is not fixed, but may be arranged to move so that the rotation axis 37 remains substantially orthogonal to the longitudinal axis 29 of the key. In the illustration of Figure 3 the pivoting element 31 is shown in a fully extended or pressed position as explained later in more detail, whereas in the illustration of Figure 4 the pivoting element 31 is shown in a position such that the upper surface of the pivoting element 31 is substantially flush with the top edge of the key shaft 22.

[0022] Figure 5 is a cross-sectional side view of the key 3a. The pivoting element 31 in this example comprises two pin engaging surfaces 39, namely a first pin engaging surface 39₁ and a second pin engaging surface 39₂, in this example facing both substantially in the same direction. The first pin engaging surface 39₁ is arranged to engage with a first key engaging surface 23 (see Figure

6a) of the first rotor pin 13₁, while the second pin engaging surface 39₂ is arranged to engage with a second key engaging surface 24 (see Figure 6a) of the second rotor pin 13₂. In this example the first key engaging surface 23 and the second key engaging surface 24 face substantially in the same direction. The first rotor pin 13₁ located in the first through hole is arranged to be urged by a first stator pin 11₁ biased by a first spring 12₁ (see Figure 6a) towards the key channel 5, while the second rotor pin 13₂ located in the second through hole is arranged to be urged by a second stator pin 11₂ biased by a second spring 12₂ towards the key channel 5 (see Figure 6a).

[0023] Figures 6a to 6c are cross-sectional lateral views illustrating in enlarged views the positions of the stator pins 11 and rotor pins 13 when inserting the key shaft 22 into the key channel 5. In Figure 6a the key is almost fully outside the key channel. In this case the springs 12 are in their extended positions and urge the stator pins 11, which further push the rotor pins 13 to be in their most distant positions from the springs 12 (the end positions being determined by the stop shoulders as discussed above). Since the stator pins 11 and therefore the rotor pins 13 are not flush with the rotor outer surface when they are in this no-key configuration, it is not possible to rotate the rotor 9 and the lock 1a cannot be unlocked or locked. The key grooves 27 are based on a key coding, which in turn have their validating means 30 in the lock 1a. The validating means 30 are in this case referred to as tumblers, which are in this example positioned in the rotor 9 parallel to the key channel 5. The rotation of the rotor 9 is being blocked by the ends of the tumblers 30, which protrude into cavities within the stator 8. In Figure 6a the tumblers 30 are in a blocking state, thus blocking the lock 1a from being unlocked. As the key 3a is being inserted into the key channel 5, the tumblers 30 are guided through the key grooves 27 which will force a vertical movement of the tumblers 30.

[0024] Figure 6b illustrates a situation where the key shaft 22 is partially inserted into the key channel 5. As can be seen, four of the central stator pins 11 and the rotor pins 13 have now moved to different vertical positions compared to the situation in Figure 6a, and thus some of the rotor pins 13 have engaged with dimples 25 in the lower edge of the key. In Figure 6b, as in Figure 6a, the rotor pins 13 have not yet reached their unlocking positions and the lock 1a cannot therefore be unlocked yet.

[0025] In Figure 6c the key shaft 22 is fully inserted in the key channel 5. In this situation, the pivoting element 31 is in its pivoted or fully extended position. This position is reached by the first rotor pin 13₁ urging the first pin engaging surface 39₁ of the pivoting element 31 upwards so that the pivoting element rotates in the clockwise direction in this example. At the same time, the second pin engaging surface 39₂ engages with the second rotor pin 13₂ and urges it downwards in this configuration. This kind of rotation of the pivoting element 31 is possible if

more torque is generated by the action of the first rotor pin 13_1 at the left hand side than is generated by the second rotor pin 13_2 on the right hand side of the pivoting element 31. Torque can be increased by increasing the spring strength of the first spring 12_1 and/or by increasing its rotational moment, i.e. the distance between the point where the force is exerted on the pivoting element 31 and the rotation axis 37. Thus in one configuration, the strengths of the first and second springs, 12_1 , 12_2 are chosen such that the first spring 12_1 it exerts a stronger force on its stator pin 11_1 than the second spring 12_2 exerts on its stator pin 11_2 . However, wear on the key 3a and the components can be reduced by creating more torque on the pivoting element by increasing the distance instead of, or in addition to, increasing the force of the dominant spring. The force exerted by the first rotor pin 13_1 on the pivoting element 31 causes the pivoting element to rotate against the biasing force of the second spring 12_2 . In this way, the rotatory movement of the pivoting element 31 controls the movement of the rotor pins 13 and more specifically in this example the movement of the second rotor pin 13_2 .

[0026] In the present description, in order to maintain consistent terminology, it will be assumed that the first rotor pin 13_1 is the dominant rotor pin (i.e. the one which exerts the greater rotational moment on the pivoting element 31. However, depending on the configuration of the pivoting element 31, the first rotor pin 13_1 could for example be the right-hand most of the rotor pins 13. In this case a greater moment would be applied on the right hand side of the pivoting element 31 than on the left hand side of the pivoting element 31, and the rotation would be in the anti-clockwise direction. As can be seen in Figure 6c, when the key shaft 22 is inserted in the key channel 5, the proximal ends (i.e. the radially outer ends) of the rotor pins 13 and the ends of the tumblers (not shown) are now flush with the rotor outer surface, thereby enabling the rotor to be rotated and thus allowing the lock 1a to be locked or unlocked. This is referred to as the unlocking position of the lock. In this position, the first rotor pin 13_1 is arranged to protrude into the key channel 5, while the second rotor pin 13_2 is held in a recessed or depressed position in the second through hole by the second pin-facing surface 39_1 of the pivoting element. According to the present invention the first and second through holes emerge into the key channel 5 at substantially the same circumferential position, with respect to the longitudinal axis, in the key channel 5.

[0027] In the example described above, the pivoting element 31 is designed such that the leading end, i.e. the end first entering the key channel, as opposed to the trailing end, is prevented or deterred from projecting out of the cavity 33 or is designed such that leading end can project only very slightly out of the cavity 33 so that this does not prevent the key 3a from being inserted into the key channel 5. This can be achieved by having for example a protrusion 41 at the trailing end of the pivoting element protruding from the cavity bottom facing side of

the pivoting element 31. In this way, the pivoting element 31 cannot rotate beyond its flush orientation in the rotational direction opposite to the pin-actuating rotational direction or can rotate only very slightly beyond this orientation. In the case shown in Figure 6a, the protrusion 41 of the upper pivoting element 31 prevents or substantially prevents the upper pivoting element from rotating beyond its flush orientation (i.e. flush or parallel with the edge of the key shaft 22) in the clockwise direction. Similarly, the protrusion 41 of the lower pivoting element 31 prevents or substantially prevents the lower pivoting element 31 from rotating beyond its flush orientation in the anti-clockwise direction. This avoids a situation in which the leading edge of the pivoting element could protrude outwards from its key edge and thereby interfere with the insertion of the key shaft 22 into the key channel 5.

[0028] Other configurations of the pivoting element 31 whose leading end is not able to protrude from its cavity 33 or is able to protrude only very slightly from the cavity 33 so that this does not prevent the key 3a from being inserted into the key channel 5 are illustrated in Figures 7 and 8. In the configuration of Figure 7, the cross-section of the cavity 33 has a substantially semi-circular shape, which is simple to manufacture. In this case, the pivoting element 31 may have a simple form. The pivoting element 31 in the configuration of Figure 8 has an opening 42 arranged to receive a rotation limiting pin 43 arranged substantially parallel to the rotation or pivot axis 37 of the pivoting element 31. Thus, in this configuration, the rotation limiting pin 43 and opening 42 limit the movement of the pivoting element 31. The shape and length of the opening 42 defines the possible range of rotational movement for the pivoting element 31. Figures 7 and 8 also identify a shoulder 47 on the rotor 9, at the opening of the key channel 5. It is also a security feature. It prevents a lock-picker from actuating the nearest rotor pin 13_2 (and therefore the angular position of the pivoting element 31) by hand. The shoulder 47 also contributes to the functioning of the pivoting element. It ensures that only keys in which the pivoting element 31 is flush with or below the edge surface of the key can be inserted into the key channel 5.

[0029] The pivoting element 31 can also be designed such that the leading end could, unless precautionary measures are taken, protrude from its cavity 33. This could impede the insertion of the key 3a into the key channel 5, as mentioned above. To overcome this issue, a biasing element 44, in this example a cavity spring, is provided in the cavity 33 to exert a rotational torque on the pivoting element 31. The cavity spring 44 acts on the pivoting element 31 such that the leading end of the pivoting element is biased in a rotational direction which results in the leading edge remaining in the cavity 33. In practical terms, the cavity spring 44 exerts a force on the trailing end of the pivoting element 31. However, as the first rotor pin 13_1 would also urge the trailing end in this scenario, the moment exerted by the rotor pin 13_1 is arranged to be stronger than the moment exerted by the

cavity spring 44 to allow the pivoting member 31 to make the desired rotational movement when the authorised key is in the unlocking position. In the example configuration of Figure 9, the cavity spring 44 is a leaf spring, whereas in the configuration of Figure 10 it is a helical spring, also known as a coil spring.

[0030] Figure 11 shows another variant of the present invention. In the configurations explained above, the pivoting elements 31 are located at the trailing end of the shaft 22 or in the trailing end region, namely one pivoting element at the top edge of the key shaft 22, and the other pivoting element 31 at the bottom edge of the key shaft 22. In the configuration of Figure 11, by contrast, the pivoting elements 31 are located at the leading end of the shaft 22, or in the leading end region, namely one pivoting element at the top edge of the key shaft 22, and the other pivoting element 31 at the bottom edge of the key shaft 22. By having the pivoting element 31 at the leading end of the shaft, more space is available at the trailing end of the shaft. On the other hand, arranging the pivoting element 31 at the leading end of the shaft may require a slimmer design of the pivoting element 31, especially if there is a groove or dimples on the lateral side of the key shaft 22.

[0031] Figure 12 shows a further variant of the present invention. In this variant there is a series of pivoting elements 31 disposed on the top and bottom side of the shaft 22. Having a series of pivoting elements arranged in the shaft makes it even more difficult to fraudulently reproduce the key 3a. Because each pivoting element 31 is associated with one or two dimples 25, of which the dimple 25₁ receiving the dominant rotor pin 13₁ can be used to code the key, the number of coding permutations is increased when compared to the number of coding permutation of a key 3a which only has known dimples and grooves. The position, size and seating depth of the pivoting element 31 in the key shaft 22 can be chosen in various ways. Thus the number of key coding permutations can be increased and various subsystems or main systems can be created that differ from each other. The geometry of the pivoting element 31 may be constant or variable in order to be able to increase the key coding combinations. The position, size and depth of the dimples may be constant or variable in order to be able to control the protrusion distance of the pivoting element 31 in the rotor 9. The interaction between the dimples 25, the rotor pins 13₁, 13₂, the pivoting element 31 (including the protrusion distance in the rotor 9) increase the number of coding permutations, since more variables are involved, which a coding system can be based upon.

[0032] Figure 13 shows a further variant of the present invention. In this variant there are three pivoting elements 31 disposed on the top and bottom side of the shaft 22. As can be seen, each of the pivoting elements, and more specifically the first pin engaging surface 39₁, is associated with a dimple 25₁, which can seat the first rotor pin 13₁. These dimples 25₁, which can seat the first rotor pin may be used for coding the key 3a. Of course the dimples

25 which are not associated with any pivoting element may also be used to code the key. The position, for example along the longitudinal axis 29 of the key 3a, size and depth of the dimples 25, 25₁ on the key or a protrusion distance of the second or third pin engaging surface 39₂, 39₃ when the first rotor pin 13₁ is seated in the dimple 25₁ associated with the first engaging surface 39₁ may be varied in order to be able to create keys which are different from each other. It is to be noted that the cross-section of the dimples 25, 25₁ may or may not be circular. Thus, the position, size and/or depth of the dimples 25, 25₁ and/or the protrusion distance may be used as coding parameters. Also the position, for example along the longitudinal axis 29 of the key, size and/or depth of the cavity 33 in which the pivoting element 31 is fitted may also vary in order to be able to create various keys, which are different from each other. It is to be noted that the dimple 25₁ associated with the first pin engaging surface 39₁ may or may not be located at the end of the cavity 33 accommodating the pivoting element 31. For example, in the configuration of Figure 13, the dimple 25₁ of the middle pivoting element 31 is not located at the end of the cavity 33, but close to the centre point of the cavity along the longitudinal axis 29 of the key shaft 22.

[0033] Figures 14 and 15 illustrate further variants of the present invention. In these variants there is provided a third rotor pin 13₃ arranged to engage with the pivoting element 31. The third rotor pin 13₃ cooperates with a third stator pin 11₃ biased by a third biasing means 12₃. In the variant of Figure 14 the pivoting element 31 has the same shape as in the configuration of Figure 5 for example. When the authorised key is in the unlocking position, the key facing end of the third rotor pin is substantially flush with the inner surface of the key channel. The variant of Figure 15 differs from the variant of Figure 14 in that the pivoting element 31 has a recess at the third rotor pin engaging surface 39₃. This means that in the unlocking position of the lock, the third rotor pin protrudes slightly into the key channel 5. The dimple 25 associated with the third pin engaging surface 39₃ may be used to code the key. In further variants it would be possible to have more than three rotor pins engaging at the same time with the pivoting element 31.

[0034] Figures 16 and 17 illustrate further variants of the present invention. In these variants, the longitudinal axis of one or more of the blind holes is oriented at an angle to the key shaft 22 as viewed in the cross-section. The cross section of Figure 16 is taken at the position of the second rotor pin 13₂ (referring for example to Figure 7) and in a plane orthogonal to the longitudinal axis of the key channel 5. The orientation of the first rotor pin 13₁ is also indicated with dashed lines. As can be seen, the first and second rotor pins 13₁, 13₂ are angled with respect to the key channel 5, such that the first and second rotor pins are not parallel to each other. The angle between the longitudinal axis of the rotor pin and the longitudinal axis of the cross section of the key channel taken in a plane orthogonal to the longitudinal axis of the key

channel can for example be in the range of 10 to 60 degrees, or more specifically between 20 and 50 degrees. The variant of Figure 15 is advantageous, if the design constraints of the lock mean that the region directly under the key channel cannot be occupied by the rotor pins 13. In the variant of Figure 17, a single pin engaging surface of the pivoting element 31 is arranged to engage with two angled rotor pins 13. Instead of only having one rotor pin 13 per pin engaging surface, having two rotor pins increases the security of the lock. Using the right tools, a lock could in theory be manipulated by trying to guess or find the unlocking position of the rotor pins 13. However, having two pins arranged as shown in Figure 17 increases the resistance against lock picking.

[0035] In the above examples, the keys are reversible. In other words the key shaft 22 can be inserted into the key channel 5 either way up. To achieve this, the same coding is applied to the top side and bottom side of the key and on both lateral sides, if they happen to have a coding pattern. This means that the top side of the key 3a has the same pivoting element configuration as the bottom side. However, the teachings of the present invention may also be applied to non-reversible keys. In this case, it is possible that the pivoting element(s) 31 is/are only provided on any one side of the key shaft 22. Alternatively, the pivoting elements may be provided on at least two sides of the key shaft 22, but using a different coding. This would further increase the number of coding permutations. The force transferring means 31 is a pivoting element 31. The movement of the first rotor pin 13_1 in a first direction causes the second rotor pin 13_2 to move in a second direction, substantially opposite to the first direction, thereby controlling the movement of the second rotor pin 39_2 . The force transferring means 31 could be a pivoting element 31 of which pivot axis is movable. To summarise, the key 3a, 3b according to the present invention is for a cylinder lock 1a, 1b as explained above. The key 3a, 3b comprises:

- the key shaft 22 for inserting into the key channel 5 of the cylinder lock 1a, 1b; and
- the force transferring means 31 disposed in the key shaft 22 and comprising the first pin engaging surface 39_1 for engaging with the first rotor pin 13_1 of the cylinder lock 1a, 1b, and the second pin engaging surface 39_2 for engaging with the second rotor pin 13_2 of the cylinder lock 1a, 1b, the force transferring means 31 being configured such that, in response to a first force exerted by the first pin 13_1 on the first pin engaging surface 39_1 in a first direction, the second pin engaging surface 39_2 exerts a second force on to the second pin 13_2 in a second direction.

[0036] The second direction is substantially opposite to the first direction. The force transferring means comprises a pivoting element arranged to pivot about a pivot axis perpendicular to a longitudinal axis of the key and the pivot axis is substantially tangential relative to the

longitudinal axis of the key. The force transferring means is located in a cavity in the key shaft, which is a blind hole.

[0037] Furthermore, to summarise, a lock 1a and such a key form part of the present invention. The lock 1a thereby comprises: a stator 8 comprising a first stator pin 111 and a second stator pin 112; a rotor 9 comprising a key-channel 5, a first rotor pin 131 and a second rotor pin 132, the rotor being rotatable in the stator 8 about a rotation axis by rotating an authorised key 3a inserted into the key channel 5, and the first and second rotor pins 131, 132 being displaceable along first and second pin channels of the rotor 9 respectively, whereby the first and second pin-channels each open into the key channel 5 at first and second pin-channel openings respectively; and biasing means 121, 122 for biasing the first and second stator pins 111, 112 towards the key channel 5 along first and second pin-channel axes respectively. The stator pins 111, 112 are arranged to align axially with the rotor pins 131, 132 when the lock is in a key-insertion state such that the first and second stator pins 111, 112 bias the first and second rotor pins 131, 132 towards the key channel 5. The first and second rotor pins 131, 132 have first and second pin lengths respectively, wherein the axial lengths are such that, when the authorised key 3a is inserted, the stator and rotor pins are displaceable by pin engaging surfaces 391, 392 of the key 3a to an unlocking position which permits the rotation of the rotor 9. The first and second pin lengths are such that, when the stator and rotor pins are in the unlocking position, the first rotor pin 131 protrudes from the first pin channel opening into the key channel 5, and the second rotor pin 132 stops short of the second pin channel opening. The first and second pin channel openings are arranged at substantially the same circumferential position in the key channel 5 relative to the rotation axis. While the invention has been illustrated and described in detail in the drawings and foregoing description, such illustration and description are to be considered illustrative or exemplary and not restrictive, the invention being not limited to the disclosed embodiment. Other embodiments and variants are understood, and can be achieved by those skilled in the art when carrying out the claimed invention, based on a study of the drawings, the disclosure and the appended claims. For example, it is possible to combine teachings from at least two variants explained above to obtain further variants.

[0038] In the claims, the word "comprising" does not exclude other elements or steps, and the indefinite article "a" or "an" does not exclude a plurality. The mere fact that different features are recited in mutually different dependent claims does not indicate that a combination of these features cannot be advantageously used. Any reference signs in the claims should not be construed as limiting the scope of the invention.

Claims

1. A key (3a, 3b) for a cylinder lock (1a, 1b), the key (3a, 3b) comprising:

- a key shaft (22) for inserting into a key channel (5) of the cylinder lock (1); and
- a force transferring means (31) disposed in the key shaft (22) and comprising a first pin engaging surface (39₁) for engaging with a first rotor pin (13₁) of the cylinder lock (1a, 1b), and a second pin engaging surface (39₂) for engaging with a second rotor pin (13₂) of the cylinder lock (1a, 1b), the force transferring means (31) being configured such that, in response to a first force exerted by the first pin (13₁) on the first pin engaging surface (39₁) in a first direction, the second pin engaging surface (39₂) exerts a second force on the second pin (13₂) in a second direction, the second direction is substantially opposite to the first direction,

wherein the force transferring means (31) comprises a pivoting element (31) arranged to pivot about a pivot axis (37) perpendicular to a longitudinal axis (29) of the key (3a, 3b),

characterised in that the pivot axis (37) is substantially tangential relative to the longitudinal axis (29) of the key (3a, 3b) and **in that** the force transferring means (31) is located in a cavity in the key shaft (22), which is a blind hole.

2. A key (3a, 3b) according to claim 1, wherein the pivot axis (37) is movable relative to key (3a, 3b).
3. A key (3a, 3b) according to claim 1 or 2, wherein the force transferring means (31) comprises a third pin engaging surface (39₃) for engaging with a third rotor pin (13₃) of the cylinder lock (1).
4. A key (3a, 3b) according to any one of the preceding claims, wherein the key (3) comprises at least two force transferring means (31).
5. A key (3a, 3b) according claim 4, wherein the at least two force transferring means (31) are arranged to engage simultaneously with the rotor pins (13) of the cylinder lock (1a, 1b).
6. A key (3a, 3b) according to claim 4, wherein the at least two force transferring means are substantially identical and located on opposite sides of the key shaft (22) substantially in an identical location relative to the longitudinal axis (29) of the key (3a, 3b).
7. A key (3a, 3b) according to any one of the preceding claims, wherein the force transferring means (31) is located in a cavity (33) in the key shaft (22), and force

transferring means biasing means (44) is provided in the cavity (33) for urging the force transferring means (31) for preventing a leading end of the force transferring means (31) from protruding out of the cavity (33) when the force transferring means (31) is not engaged with rotor pins (13).

8. A key (3a, 3b) according to any one of the preceding claims, wherein the force transferring means (31) is located in a cavity (33) in the key shaft (22), and a rotation limiting means (41, 42, 43) is provided in the cavity (33) for limiting the range of rotation of the force transferring means (31).
9. A key (3a, 3b) according to any one of the preceding claims, wherein the key (3a, 3b) comprises a first dimple (25₁) for receiving an end of the first rotor pin (13₁).
10. A cylinder lock (1a, 1b) and the key (3a, 3b) according to any one of the preceding claims, the lock (1a, 1b) further comprising:

- a stator (8) comprising a first a stator pin (11₁), and a second stator pin (11₂);
- a rotor (9) comprising a key channel (5) for receiving the key (3a, 3b), the rotor (9) being arranged to be rotated in the stator (8) about a longitudinal axis of the key channel (5) by turning an authorised key (3a, 3b) in the key channel (5);
- biasing means for biasing the first stator pin (11₁) and a second stator pin (11₂) towards the key channel (5);
- a first pin channel in the rotor (9) for accommodating a first rotor pin (13₁) arranged to cooperate with the first stator pin (11₁), and a second pin channel in the rotor (9) for accommodating a second rotor pin (13₂) arranged to cooperate with the second stator pin (11₂), the first and second rotor pins (13₁, 13₂) being arranged to engage with the key (3a, 3b), wherein

in an unlocking position of the lock (1a, 1b), the first rotor pin (13₁) is arranged to protrude into the key channel (5), while a key facing end of the second rotor pin (13₂) is located recessed in the second pin channel, and wherein the first and second pin channels emerge into the key channel (5) at substantially the same circumferential position, with respect to the longitudinal axis, in the key channel (5).

11. A cylinder lock (1a, 1b) according to claim 10, wherein the first rotor pin (13₁) and the second rotor pin (13₂) are angled with respect to each other, and the angle between the first rotor pin (13₁) and the second rotor pin (13₂) is between 10 and 60 degrees and more preferably between 20 and 50 degrees.

12. A method of coding a key according to any one of claims 1 to 9, wherein at least one of the following parameters is used to code the key (3a, 3b): a diameter of the cross-section of the first dimple (25₁), a depth of the first dimple (25₁), a position of the first dimple (25₁) along a longitudinal axis (29) of the key (3a, 3b), a protrusion distance of the second pin engaging surface (39₂) when the first rotor pin (13₁) is seated in the first dimple (25₁), and a location along a longitudinal axis (29) of the key (3a, 3b) of a cavity (33) accommodating the force transferring means (31).

Patentansprüche

1. Ein Schlüssel (3a, 3b) für ein Zylinderschloss (1a, 1b), wobei der Schlüssel (3a, 3b) umfasst:

- einen Schlüsselschaft (22) zum Einsetzen in einen Schlüsselkanal (5) des Zylinderschlosses (1); und
- eine Kraftübertragungsvorrichtung (31), die in dem Schlüsselschaft (22) angeordnet ist und eine erste Stiftkontaktfläche (39₁) zum Kontakt mit einem ersten Rotorstift (13₁) des Zylinderschlosses (1a, 1b), und eine zweite Stiftkontaktfläche (39₂) zum Kontakt mit einem zweiten Rotorstift (13₂) des Zylinderschlosses (1a, 1b) umfasst, wobei die Kraftübertragungsvorrichtung (31) derart konfiguriert ist, dass als Reaktion auf eine erste von dem ersten Stift (13₁) ausgeübte Kraft auf die erste Stifteingriffsfläche (39₁) in einer ersten Richtung, die zweite Stifteingriffsfläche (39₂) eine zweite Kraft auf den zweiten Stift (13₂) in einer zweiten Richtung ausübt, wobei die zweite Richtung im Wesentlichen entgegengesetzt zur ersten Richtung ist,

wobei die Kraftübertragungsvorrichtung (31) ein drehbares Element (31) umfasst, das um eine Drehachse (37) senkrecht zu einer Längsachse (29) des Schlüssels (3a, 3b) drehen kann,

dadurch gekennzeichnet, dass die Drehachse (37) im Wesentlichen tangential zur Längsachse (29) des Schlüssels (3a, 3b) ist und, dass die Kraftübertragungsvorrichtung (31) in einem Hohlraum in dem Schlüsselschaft (22) angeordnet ist, der ein Sackloch ist.

2. Der Schlüssel (3a, 3b) gemäss dem Anspruch 1, wobei die Drehachse (37) relativ zum Schlüssel (3a, 3b) bewegbar ist.
3. Der Schlüssel (3a, 3b) gemäss dem Anspruch 1 oder 2, wobei die Kraftübertragungsvorrichtung (31) eine dritte Stiftkontaktfläche (39₃) zum Kontakt mit einem dritten Rotorstift (13₃) des Zylinderschlosses (1) um-

fasst.

4. Der Schlüssel (3a, 3b) gemäss einem der vorherigen Ansprüche, wobei der Schlüssel (3a, 3b) mindestens zwei Kraftübertragungsvorrichtungen (31) umfasst.

5. Der Schlüssel (3a, 3b) gemäss dem Anspruch 4, wobei die mindestens zwei Kraftübertragungsvorrichtungen (31) so angeordnet sind, dass sie gleichzeitig mit den Rotorstiften (13) des Zylinderschlosses (1a, 1b) in Kontakt zu kommen.

6. Der Schlüssel (3a, 3b) gemäss dem Anspruch 4, wobei die mindestens zwei Kraftübertragungsvorrichtungen im Wesentlichen identisch sind und auf den gegenüberliegenden Seiten des Schlüsselschaftes (22) im Wesentlichen an einer identischen Stelle relativ zu der Längsachse (29) des Schlüssels angeordnet sind.

7. Der Schlüssel (3a, 3b) gemäss einem der vorherigen Ansprüche, wobei die Kraftübertragungsvorrichtung (31) in einem Hohlraum (33) in dem Schlüsselschaft (22) angeordnet ist, und wobei eine Vorspannvorrichtung (44) der Kraftübertragungsvorrichtung in dem Hohlraum (33) vorgesehen ist, um die Kraftübertragungsvorrichtung (31) zurückzuhalten, um zu verhindern, dass ein vorderes Ende der Kraftübertragungsvorrichtung (31) aus dem Hohlraum (33) herausragt, wenn die Kraftübertragungsvorrichtung (31) nicht im Kontakt mit Rotorstiften (13) steht.

8. Der Schlüssel (3a, 3b) gemäss einem der vorherigen Ansprüche, wobei die Kraftübertragungsvorrichtung (31) in einem Hohlraum (33) in dem Schlüsselschaft (22) angeordnet ist, und wobei eine Drehbegrenzungseinrichtung (41, 42, 43) in dem Hohlraum (33) vorgesehen ist, um den Drehbereich der Kraftübertragungsvorrichtung (31) zu begrenzen.

9. Der Schlüssel (3a, 3b) gemäss einem der vorherigen Ansprüche, wobei der Schlüssel (3a, 3b) eine erste Vertiefung (25₁) zum Aufnehmen eines Endes des ersten Rotorstiftes (13₁) umfasst.

10. Ein Zylinderschloss (1a, 1b) und der Schlüssel (3a, 3b) gemäss einem der vorherigen Ansprüche, wobei das Schloss (1a, 1b) ferner umfasst

- einen Stator (8) mit einem ersten Statorstift (11₁) und einem zweiten Statorstift (11₂);
- einen Rotor (9) mit einem Schlüsselkanal (5) zur Aufnahme eines Schlüssels (3a, 3b), wobei der Rotor (9) in dem Stator (8) um eine Längsachse des Schlüsselkanals (5) drehbar angeordnet ist durch Drehen eines autorisierten Schlüssels (3a, 3b) in dem Schlüsselkanal (5);
- eine Vorspannvorrichtung zum Vorspannen

des ersten Statorstiftes (11₁) und eines zweiten Statorstiftes (11₂) in Richtung des Schlüsselkanals (5);

- einen ersten Stiftkanal in dem Rotor (9) zum Aufnehmen eines ersten Rotorstiftes (13₁), der zum Zusammenwirken mit dem ersten Statorstift (11₁) angeordnet ist, und einen zweiten Stiftkanal in dem Rotor (9) zum Aufnehmen eines zweiten Rotorstiftes (13₂), der zum Zusammenwirken mit dem zweiten Statorstift (11₂) angeordnet ist, wobei der erste und der zweite Rotorstift (13₁, 13₂) angeordnet sind, um mit dem Schlüssel (3a, 3b) in Kontakt zu kommen, wobei

in einer Entriegelungsposition des Schlosses (1a, 1b) der erste Rotorstift (13₁) so angeordnet ist, dass er in den Schlüsselkanal (5) hineinragt, während ein dem Schlüssel zugewandtes Ende des zweiten Rotorstiftes (13₂) in dem zweiten Stiftkanal versenkt angeordnet ist, und wobei der erste und der zweite Stiftkanal in den Schlüsselkanal (5) im Wesentlichen in der gleichen Umfangsposition, in Bezug auf die Längsachse, in dem Schlüsselkanal (5) münden.

11. Das Zylinderschloss (1a, 1b) gemäss dem Anspruch 10, wobei der erste Rotorstift (13₁) und der zweite Rotorstift (13₂) zueinander in einem Winkel stehen, und wobei der Winkel zwischen dem ersten Rotorstift (13₁) und dem zweiten Rotorstift (13₂) zwischen 10 und 60 Grad und vorzugsweise zwischen 20 und 50 Grad beträgt.
12. Ein Verfahren zum Codieren eines Schlüssels gemäss einem der Ansprüche 1 bis 9, wobei mindestens einer der folgenden Parameter zum Codieren des Schlüssels (3a, 3b) verwendet wird: ein Durchmesser des Querschnitts der ersten Vertiefung (25₁), eine Tiefe der ersten Vertiefung (25₁), eine Position der ersten Vertiefung (25₁) entlang einer Längsachse (29) des Schlüssels (3a, 3b), eine Vorstehdistanz der zweiten Stiftkontaktfläche (39₂), wenn der erste Rotorstift (13₁) in der ersten Vertiefung (25₁) sitzt, und eine Stelle entlang einer Längsachse (29) des Schlüssels (3a, 3b) eines die Kraftübertragungsvorrichtung (31) aufnehmenden Hohlraums (33).

Revendications

1. Une clé (3a, 3b) pour une serrure à cylindre (1a, 1b), la clé (3a, 3b) comprenant :
 - un arbre de clé (22) à insérer dans un canal de clé (5) de la serrure à cylindre (1) ; et
 - un moyen de transfert de force (31) disposé dans l'arbre de clé (22) et comprenant une pre-

mière surface d'engagement de goupille (39₁) pour coopérer avec une première goupille de rotor (13₁) de la serrure à cylindre (1a, 1b) et une deuxième surface d'engagement de goupille (39₂) pour coopérer avec une deuxième goupille de rotor (13₂) de la serrure à cylindre (1a, 1b), le moyen de transfert de force (31) étant configuré de sorte que, en réponse à une première force exercée par la première goupille (13₁) sur la première surface d'engagement de goupille (39₁) dans une première direction, la deuxième surface d'engagement de goupille (39₂) exerce une deuxième force sur la deuxième goupille (13₂) dans une deuxième direction, la deuxième direction étant sensiblement opposée à la première direction,

dans laquelle le moyen de transfert de force (31) comprend un élément pivotant (31) agencé pour pivoter autour d'un axe de pivotement (37) perpendiculaire à un axe longitudinal (29) de la clé (3a, 3b), **caractérisée en ce que** l'axe de pivotement (37) est sensiblement tangentiel par rapport à l'axe longitudinal (29) de la clé (3a, 3b) et **en ce que** le moyen de transfert de force (31) est situé dans une cavité dans l'arbre de clé (22), qui est un trou borgne.

2. La clé (3a, 3b) selon la revendication 1, dans laquelle l'axe de pivotement (37) est mobile par rapport à la clé (3a, 3b).
3. La clé (3a, 3b) selon la revendication 1 ou 2, dans laquelle le moyen de transfert de force (31) comprend une troisième surface d'engagement de goupille (39₃) pour coopérer avec une troisième goupille de rotor (13₃) de la serrure à cylindre (1).
4. La clé (3a, 3b) selon l'une quelconque des revendications précédentes, dans laquelle la clé (3) comprend au moins deux moyens de transfert de force (31).
5. La clé (3a, 3b) selon la revendication 4, dans laquelle les au moins deux moyens de transfert de force (31) sont agencés pour coopérer simultanément avec les goupilles de rotor (13) de la serrure à cylindre (1a, 1b).
6. La clé (3a, 3b) selon la revendication 4, dans laquelle les au moins deux moyens de transfert de force sont sensiblement identiques et situés sur les côtés opposés de l'arbre de clé (22) sensiblement à un emplacement identique par rapport à l'axe longitudinal (29) de la clé (3a, 3b).
7. La clé (3a, 3b) selon l'une quelconque des revendications précédentes, dans laquelle le moyen de transfert de force (31) est situé dans une cavité (33)

dans l'arbre de clé (22) et un moyen de sollicitation de moyen de transfert de force (44) est prévu dans la cavité (33) pour solliciter le moyen de transfert de force (31) pour empêcher qu'une extrémité avant du moyen de transfert de force (31) sorte de la cavité (33) lorsque le moyen de transfert de force (31) ne coopère pas avec des goupilles de rotor (13).

8. La clé (3a, 3b) selon l'une quelconque des revendications précédentes, dans laquelle le moyen de transfert de force (31) est situé dans une cavité (33) dans l'arbre de clé (22), et un moyen de limitation de rotation (41, 42, 43) est prévu dans la cavité (33) pour limiter la plage de rotation du moyen de transfert de force (31). 10
9. La clé (3a, 3b) selon l'une quelconque des revendications précédentes, dans laquelle la clé (3a, 3b) comprend une première fossette (25₁) pour recevoir une extrémité de la première goupille de rotor (13₁). 20
10. Une serrure à cylindre (1a, 1b) et la clé (3a, 3b) selon l'une quelconque des revendications précédentes, la serrure (1a, 1b) comprenant de plus : 25
- un stator (8) comprenant une première goupille de stator (11₁) et une deuxième goupille de stator (11₂) ;
 - un rotor (9) comprenant un canal de clé (5) pour recevoir une clé (3a, 3b), le rotor (9) étant agencé pour tourner dans le stator (8) autour d'un axe longitudinal du canal de clé (5) en tournant une clé autorisée (3a, 3b) dans le canal de clé (5) ; 30
 - des moyens de sollicitation pour solliciter la première goupille de stator (11₁) et une deuxième goupille de stator (11₂) dans la direction du canal de clé (5) ; 35
 - un premier canal de goupille dans le rotor (9) pour recevoir une première goupille de rotor (13₁) agencée pour coopérer avec la première goupille de stator (11₁), et un deuxième canal de goupille dans le rotor (9) pour recevoir une deuxième goupille de rotor (13₂) agencée pour coopérer avec la deuxième goupille de stator (11₂), les première et deuxième goupilles de rotor (13₁, 13₂) étant agencées pour coopérer avec la clé (3a, 3b), dans laquelle 40

dans une position de déverrouillage de la serrure (1a, 1b), la première goupille de rotor (13₁) est disposée pour faire saillie dans le canal de clé (5), tandis qu'une extrémité faisant face à la clé de la deuxième goupille de rotor (13₂) est située en retrait dans le deuxième canal de goupille, 50

caractérisée en ce que les premier et deuxième canaux de goupille débouchent dans le canal de clé (5) sensiblement à la même position circonférentiel- 55

le, par rapport à l'axe longitudinal, dans le canal de clé (5).

11. La serrure à cylindre (1a, 1b) selon la revendication 10, dans laquelle la première goupille de rotor (13₁) et la deuxième goupille de rotor (13₂) sont inclinées l'une par rapport à l'autre, et l'angle entre la première goupille de rotor (13₁) et la deuxième goupille de rotor (13₂) est compris entre 10 et 60 degrés et plus préférentiellement entre 20 et 50 degrés. 5
12. Un procédé de codage d'une clé selon l'une quelconque des revendications 1 à 9, dans lequel au moins l'un des paramètres suivants est utilisé pour coder la clé (3a, 3b) : un diamètre de la section transversale de la première fossette (25₁), une profondeur de la première fossette (25₁), une position de la première fossette (25₁) le long d'un axe longitudinal (29) de la clé (3a, 3b), une distance de saillie de la deuxième surface d'engagement de goupille (39₂) lorsque la première goupille de rotor (13₁) est logée dans la première fossette (25₁), et un emplacement le long d'un axe longitudinal (29) de la clé (3a, 3b) d'une cavité (33) logeant le moyen de transfert de force (31). 10 15 20 25 30 35 40 45 50 55

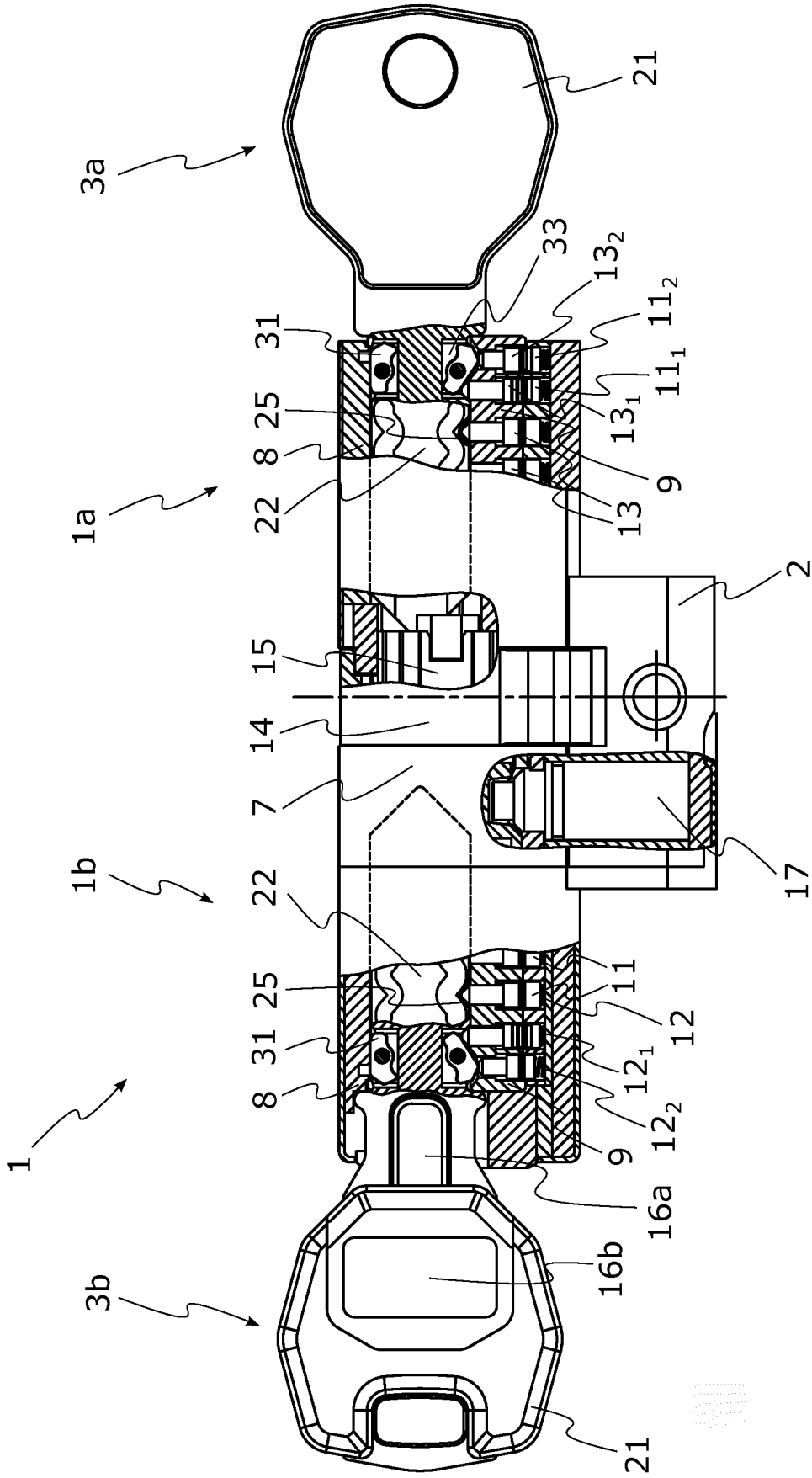
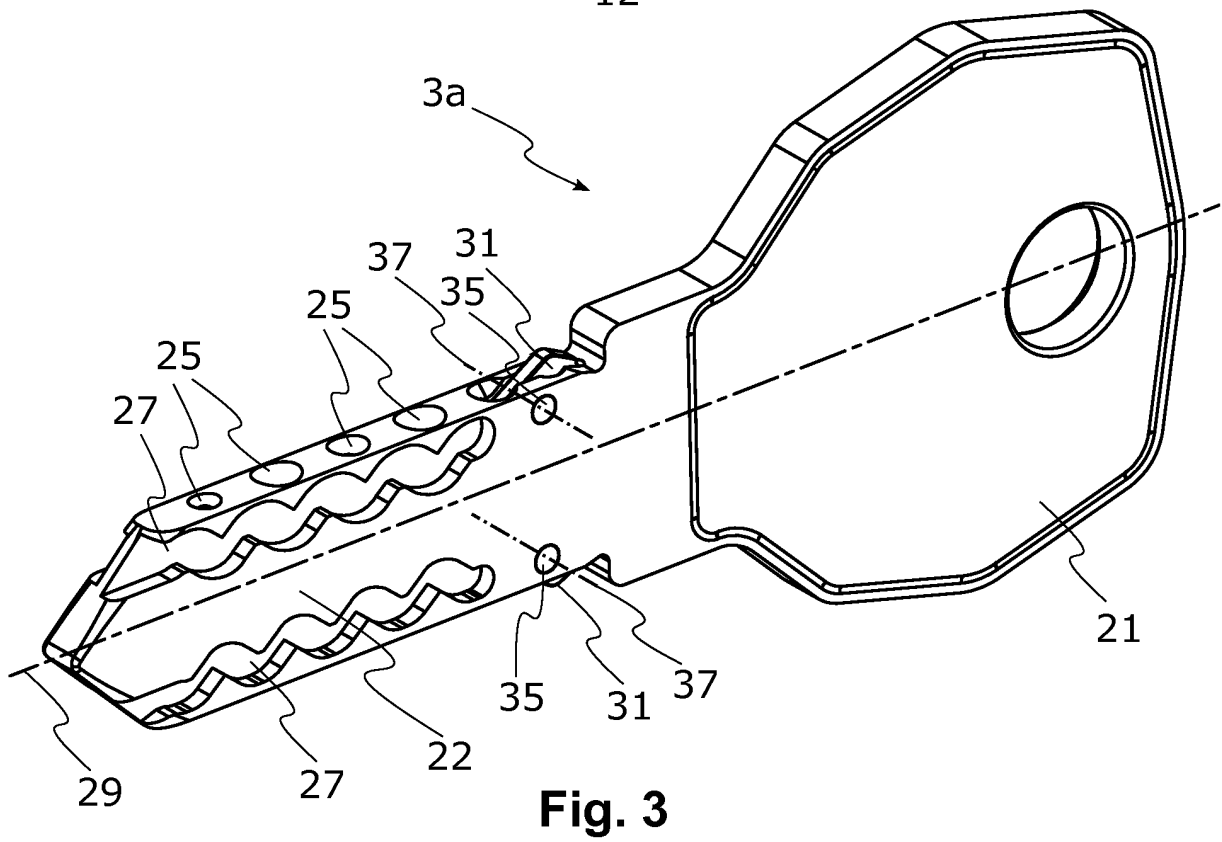
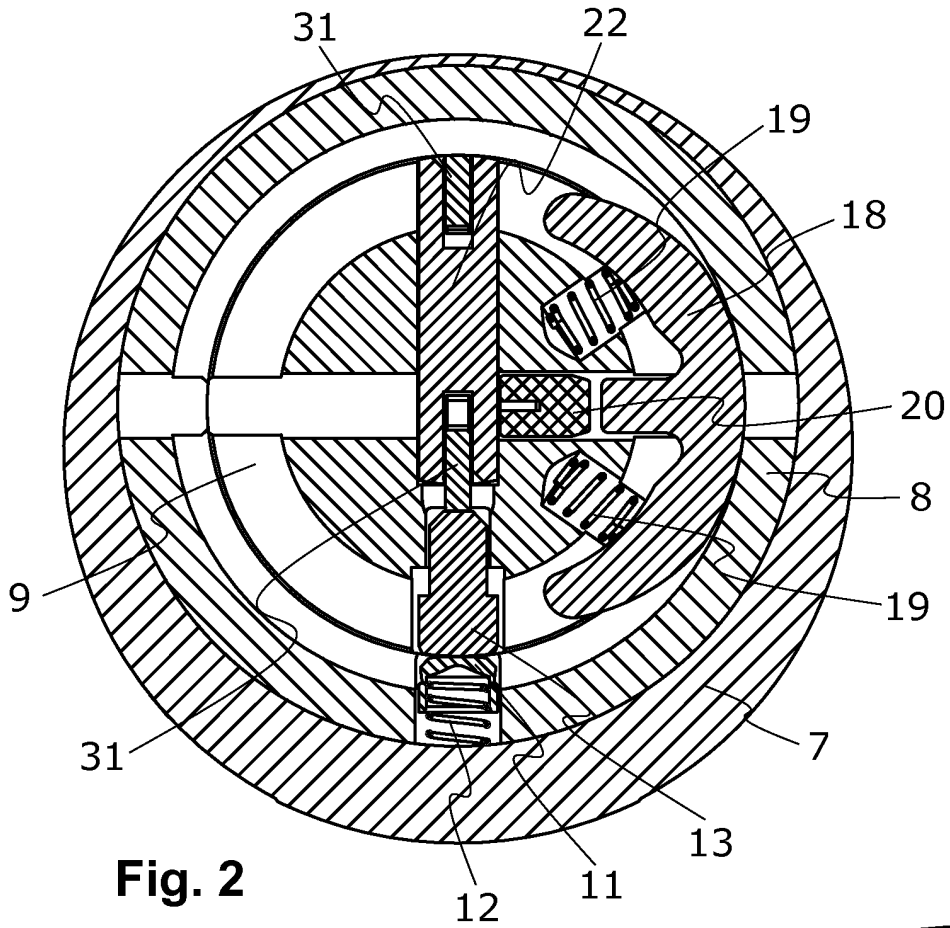

Fig. 1



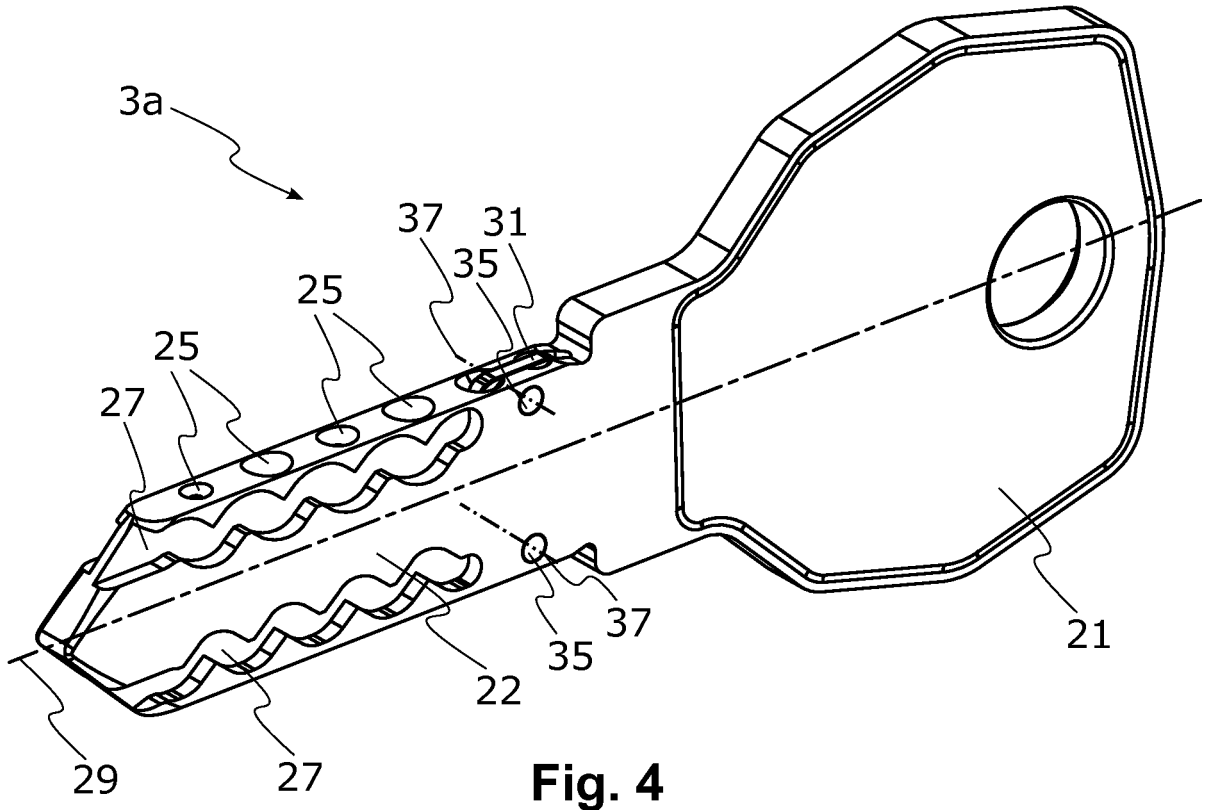

Fig. 4

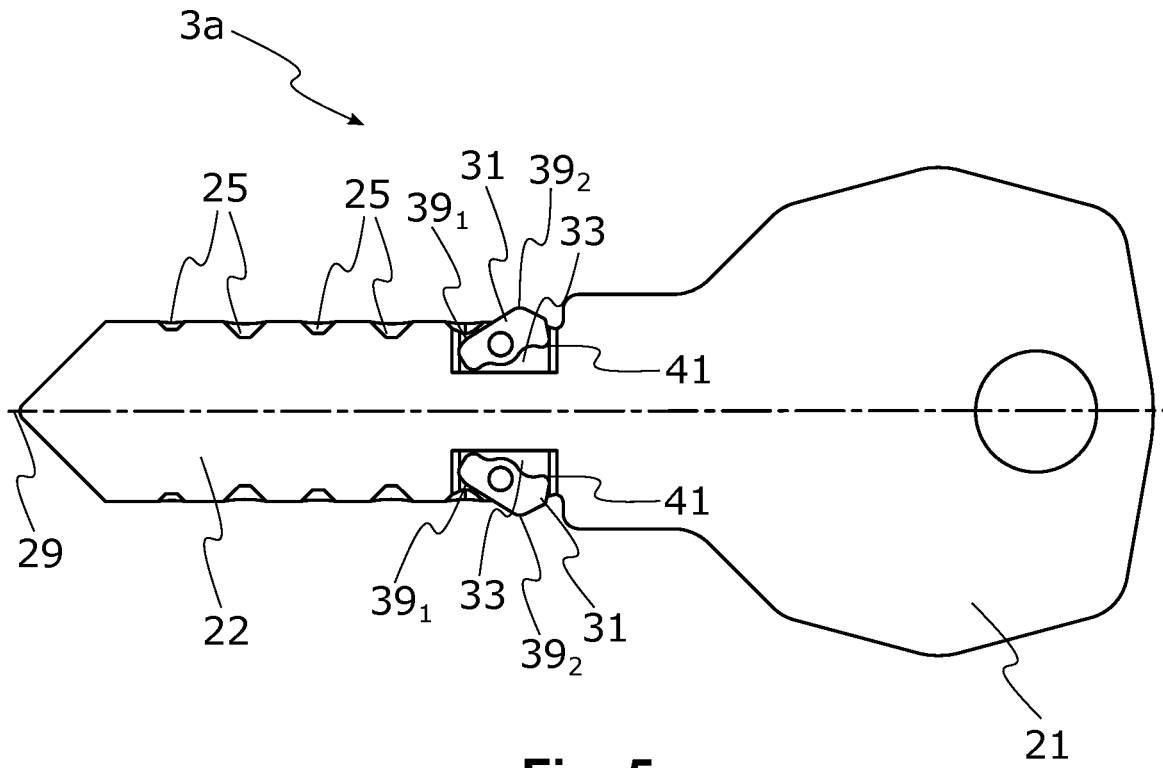

Fig. 5

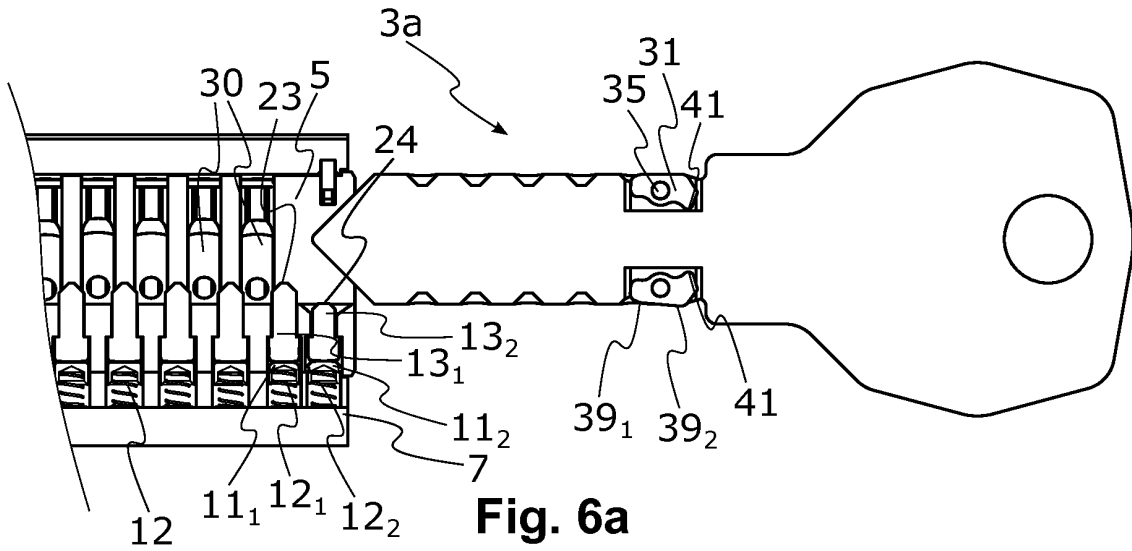

Fig. 6a

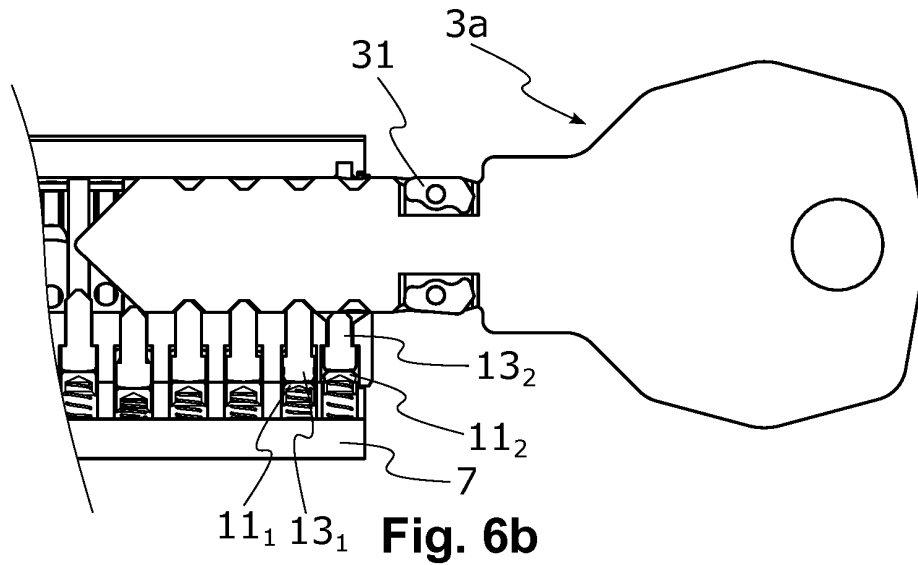

Fig. 6b

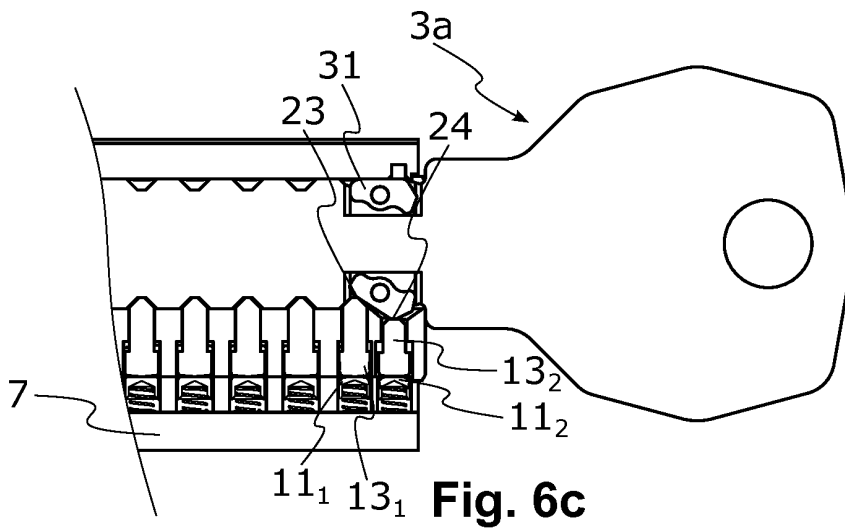

Fig. 6c

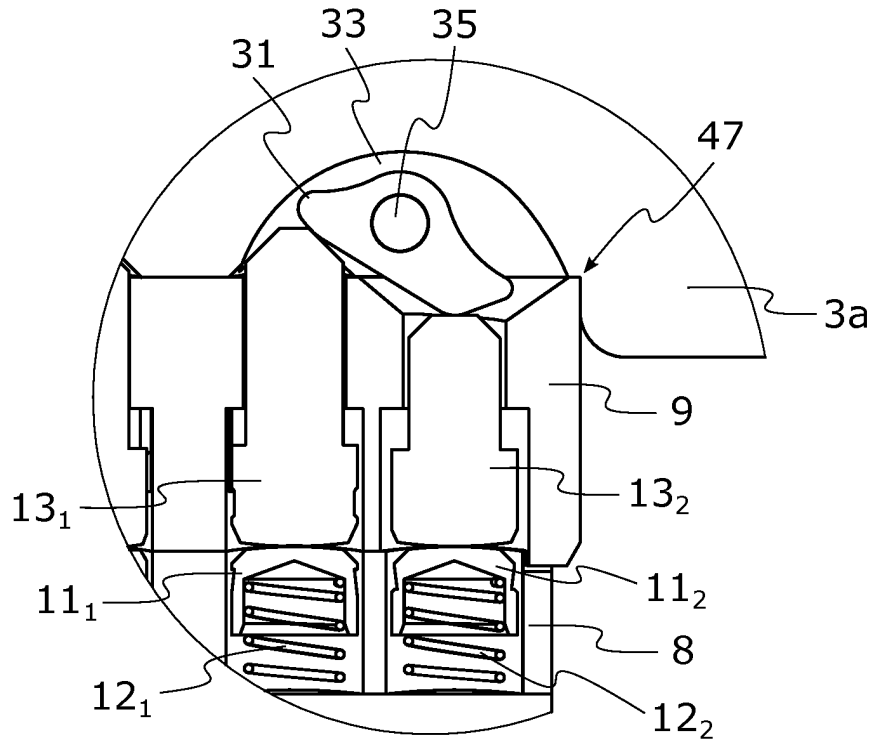

Fig. 7

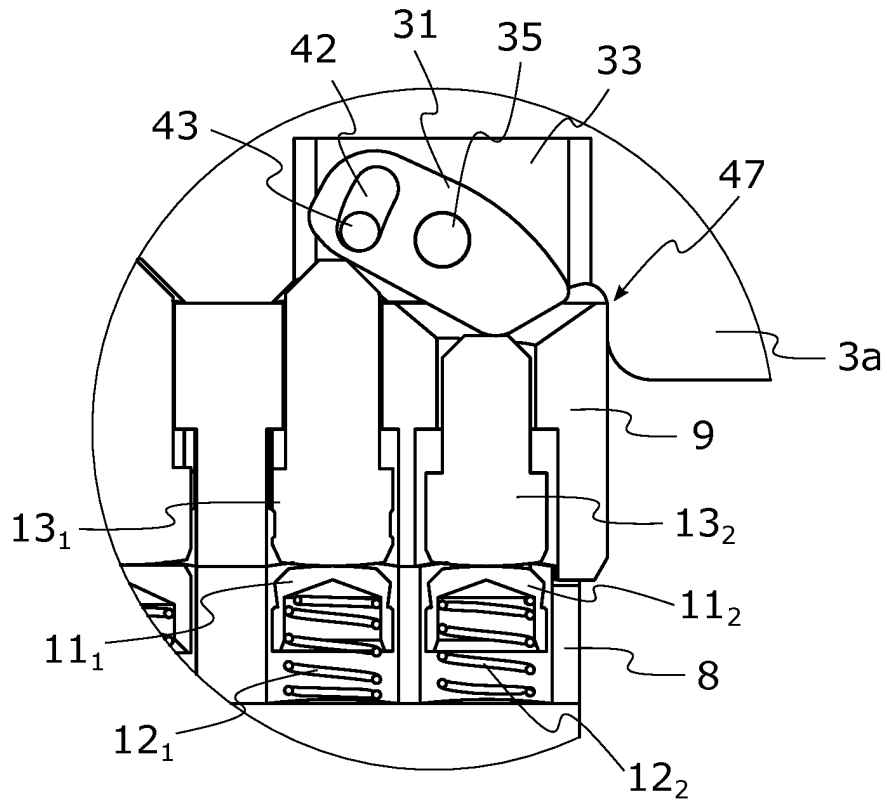
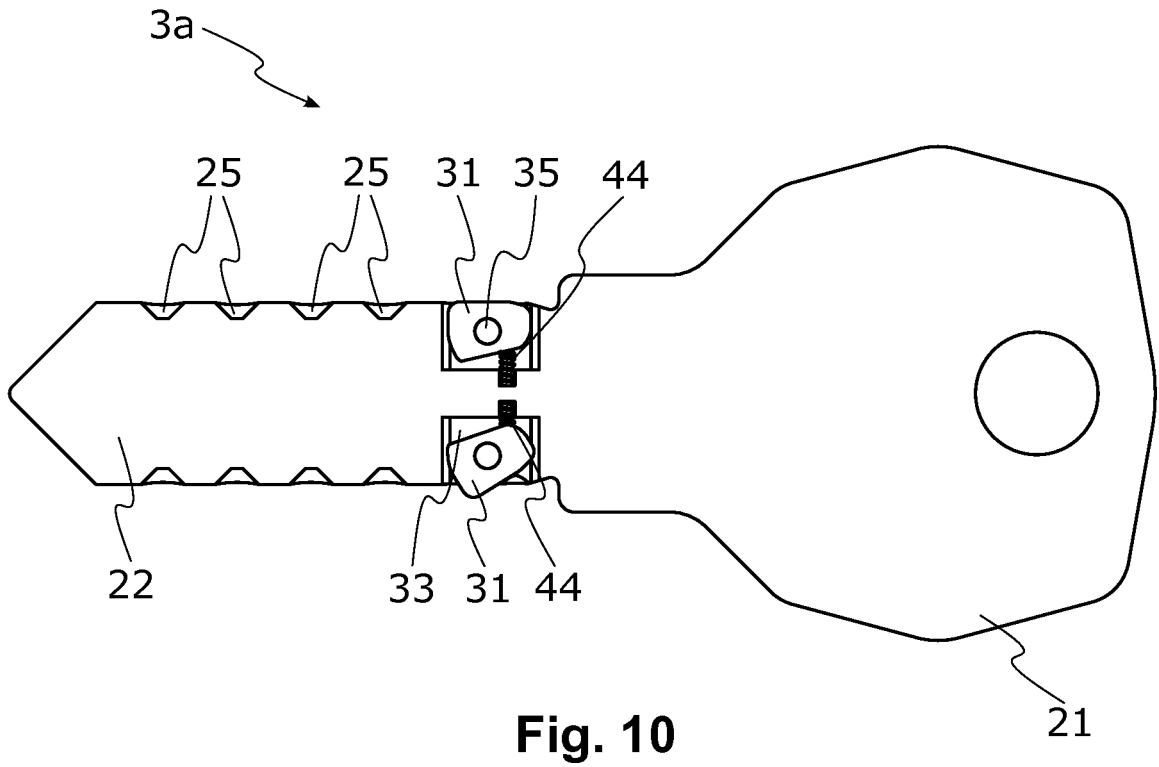
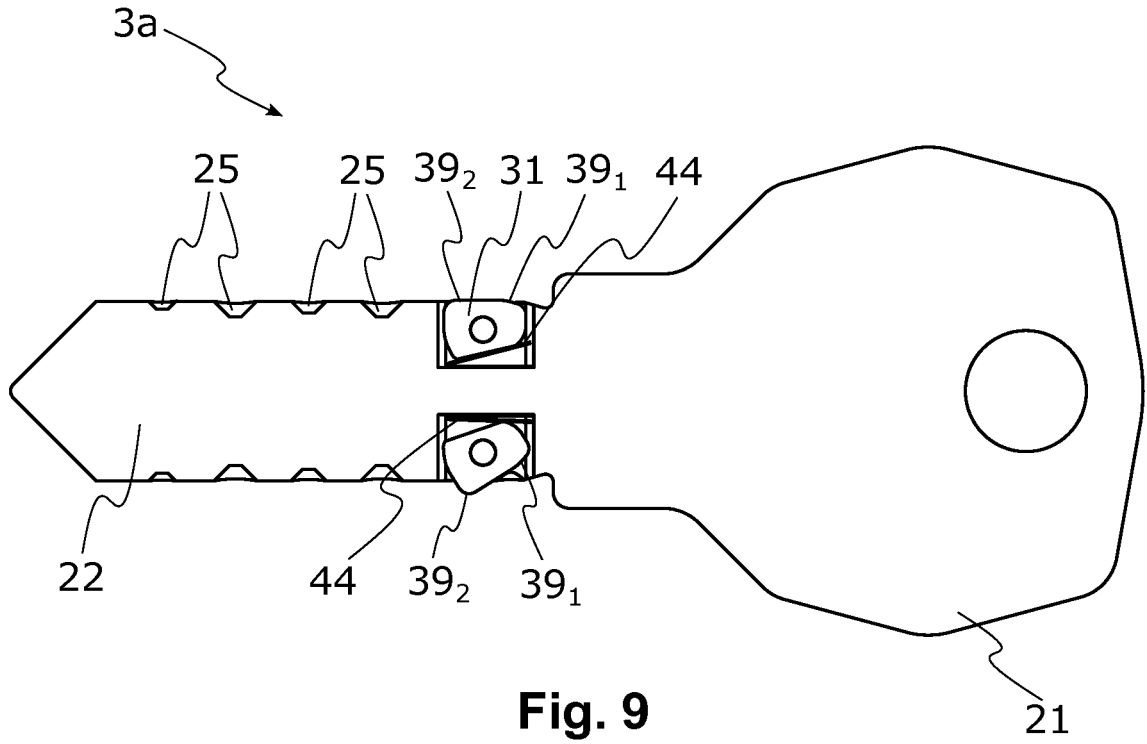
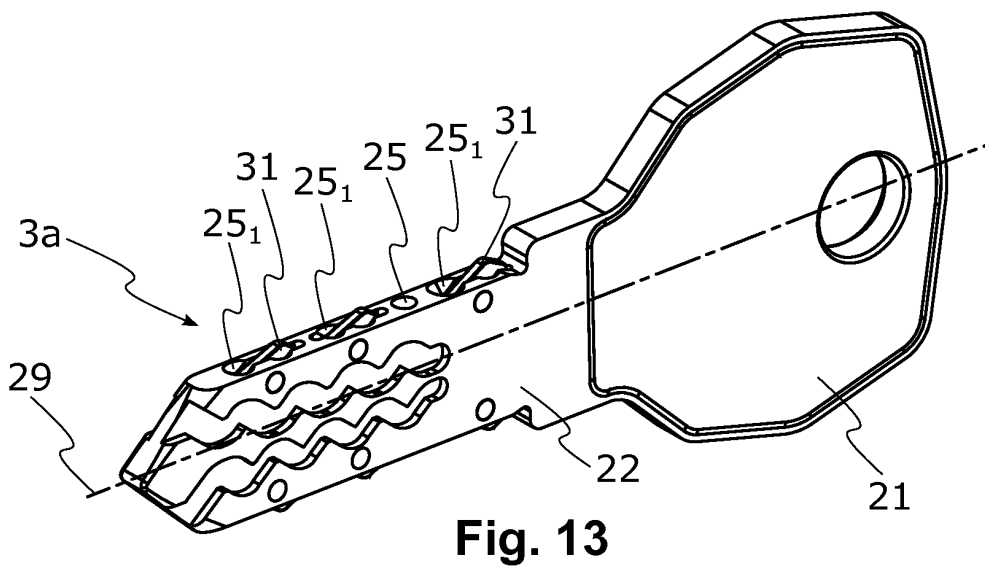
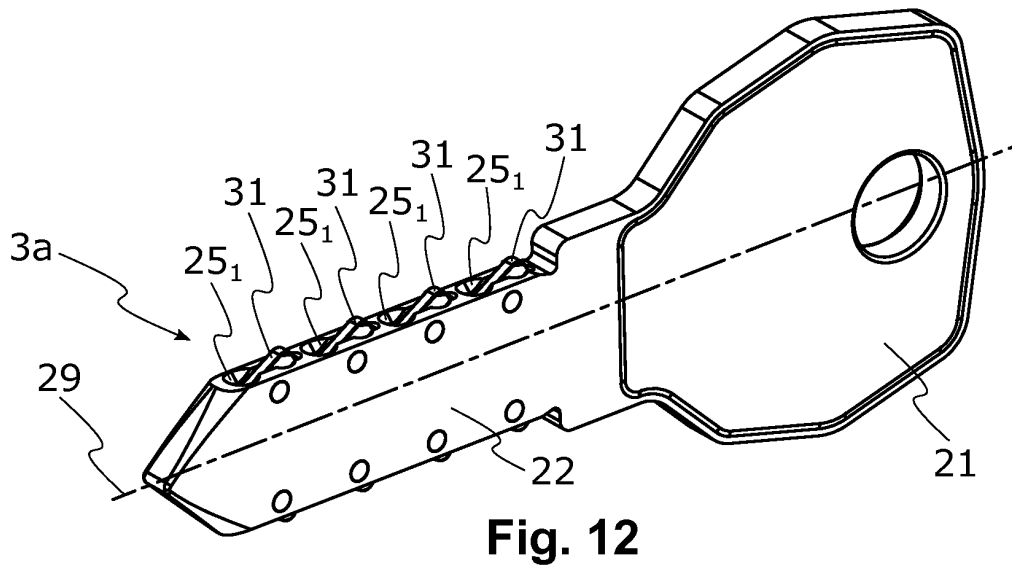
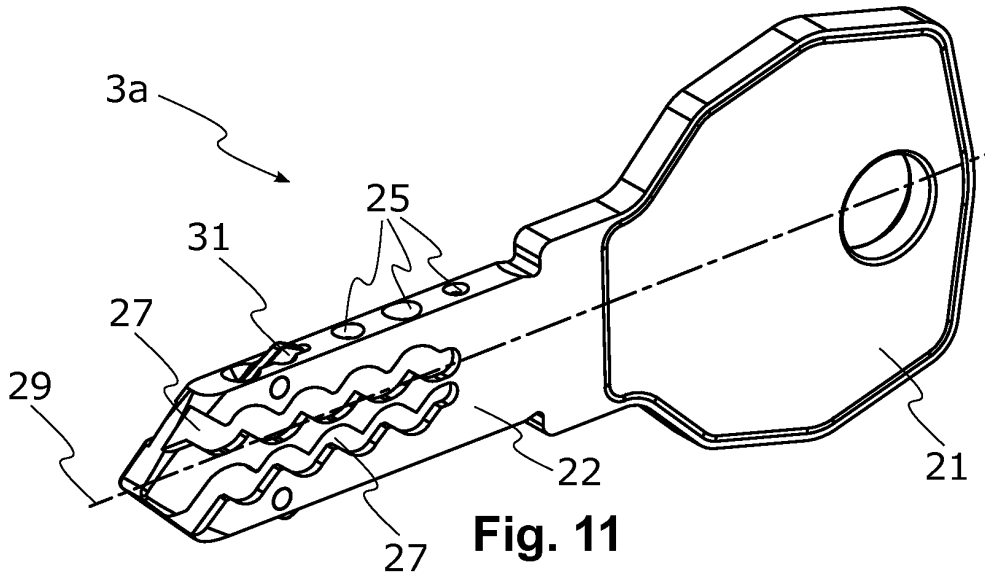

Fig. 8





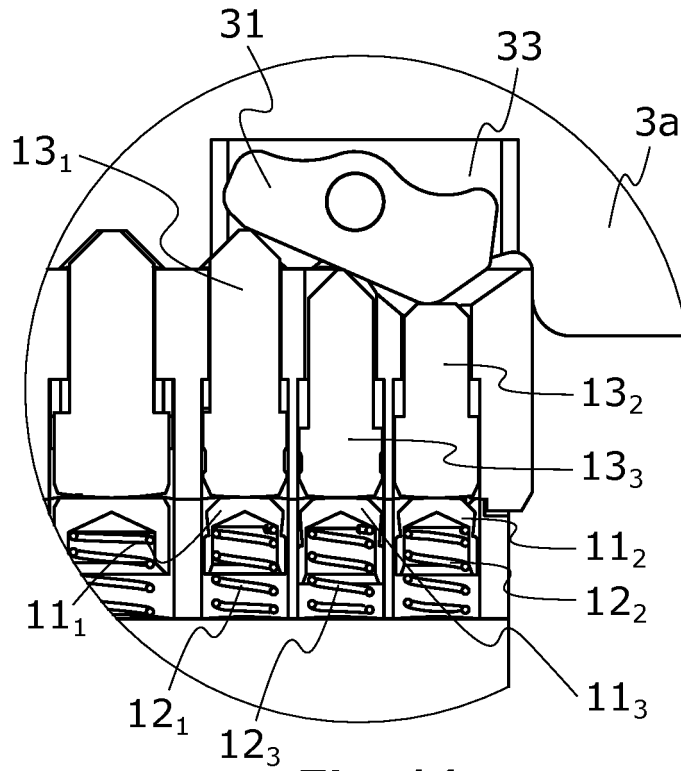

Fig. 14

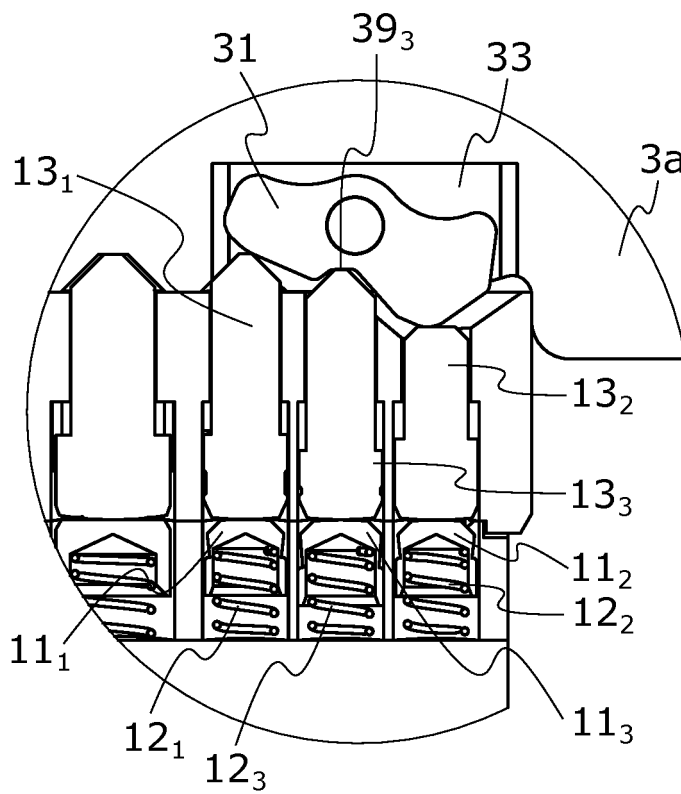
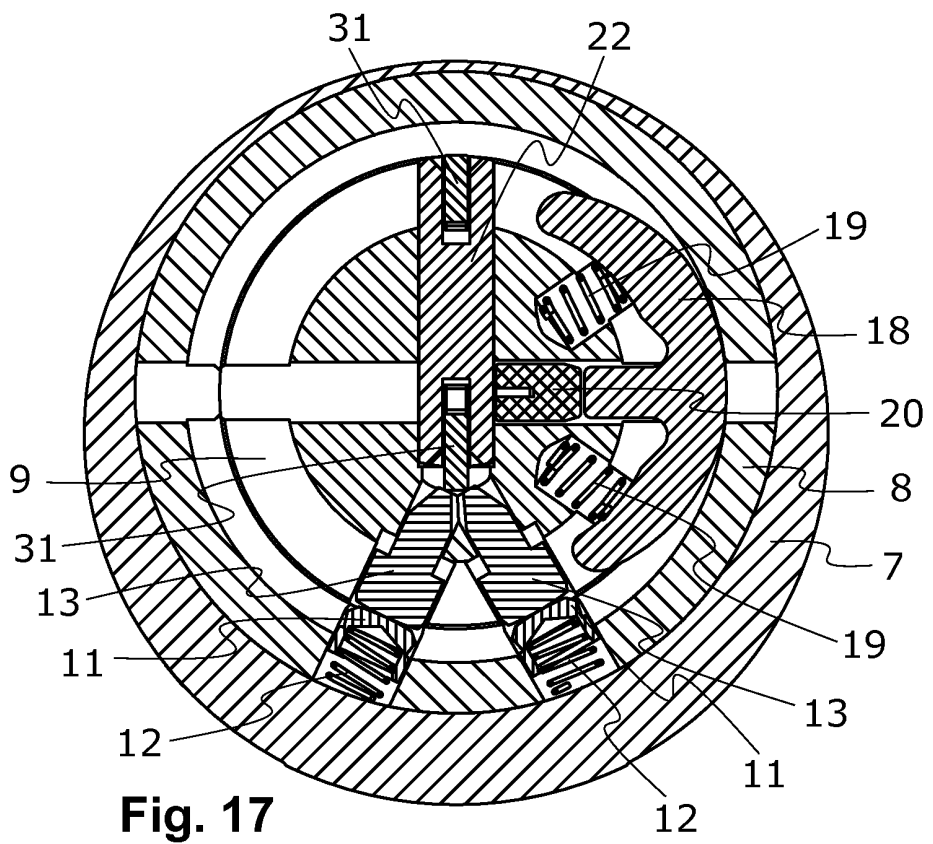
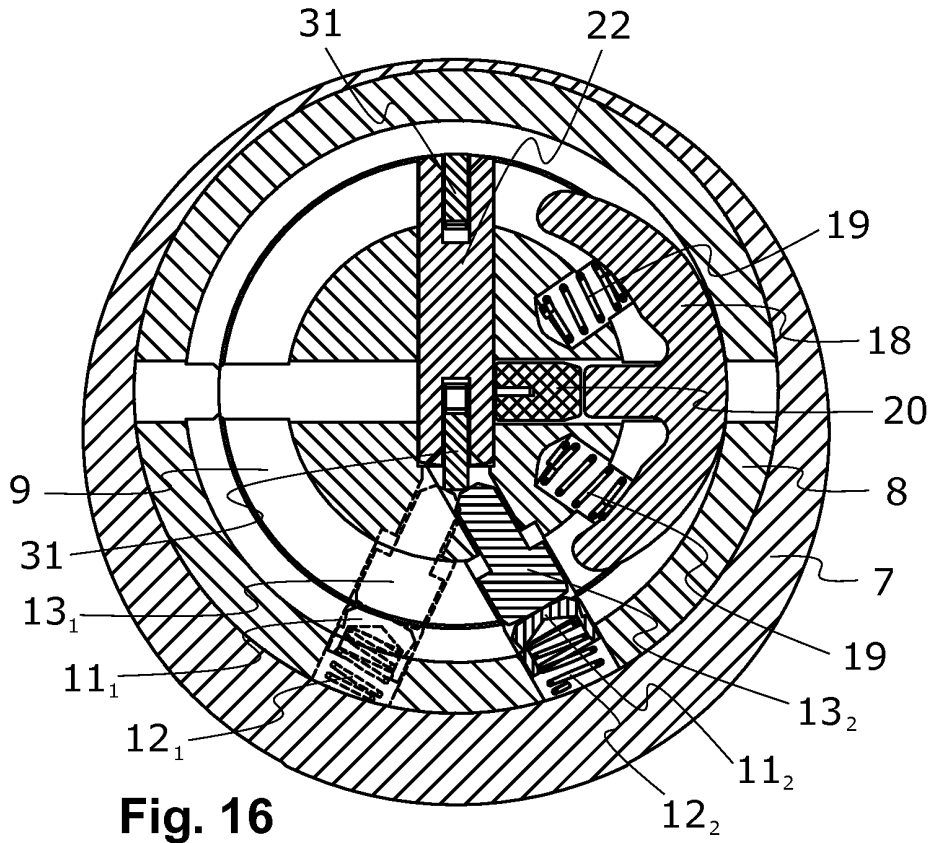

Fig. 15



REFERENCES CITED IN THE DESCRIPTION

This list of references cited by the applicant is for the reader's convenience only. It does not form part of the European patent document. Even though great care has been taken in compiling the references, errors or omissions cannot be excluded and the EPO disclaims all liability in this regard.

Patent documents cited in the description

- ES 2088345 [0006]
- EP 0416500 A [0006]
- WO 2015063755 A [0007]
- EP 0890694 A [0008]
- CH 4077989 [0016]
- WO 9828508 A [0016]